

PINO The Humanoid that Walk

Fuminori Yamasaki^{1,2}, Tatsuya Matsui¹, Takahiro Miyashita¹, and Hiroaki Kitano^{1,3}

¹ Kitano Symbiotic Systems Project, ERATO, JST
yamasaki@symbio.jst.go.jp

² Osaka University

³ Sony CSL

Abstract. In this paper, we present a basic architecture and design principle behind Pino. Pino is designed to be a platform for research in robotics and AI. There are four major issues in Pino's design; high DOF system to realize various kind of behaviors, sensory system in order to recognize the exteroceptive and interoceptive information, consisting of cheap and off-the-shelf components, adequate size and exterior to be able to consider the interaction with the environment. Grounding to these issues, we developed the humanoid robot Pino. And we had a preliminary experiment in order to verify that Pino can walk in the real world.

1 Introduction

RoboCup Humanoid League [1], expected to start from 2002, is one of the most attractive research target. It seems that humanoid have increased attention as the research target around the world. But it is a general impression that humanoid research is extremely expensive, thus it is beyond the capability of the most research group. This is partly true if we are to design all components from scratch aiming at honda P3 [2] level humanoid. Thus, it is important basic architectures for cheap and reliable research platform for humanoid to be quickly established. This paper describes how we approach these issues within Pino the humanoid (see Fig.1). As a preliminary experiment we verify that Pino can control foot position and posture, and walk based on PTP control [3] in the real world.

There are four major issues addressed in this paper, (1) it can generate various kind of behaviors, (2) it has various kinds of sensors in order to recognize exteroceptive and interoceptive information, (3) it is consisted of cheap and off-the-shelf components, and (4) it has the adequate size and exterior to be able to consider the interaction with the environment.

First, it is necessary that humanoid should have high degrees of freedom (DOF) so that it can achieve various kind of behaviors. In RoboCup Humanoid League, for example, humanoid searches a ball and two goals, and moves to its desired location with avoiding many obstacles. These maneuver involve the some fundamental motions; keeping its body's balance, moving the swing leg, operation a grasping object, and controlling visual attention. High DOFs make it possible to achieve these motions in parallel.

Second, in case of achieving these motions, the robot needs various kinds of sensors in order to recognize the exteroceptive and interoceptive information. These sensors are used for interaction with the environment and recognition of own state.

Third, it is beyond the capability of the most research group if we are to design all components from scratch aiming at honda P3 level humanoid. It is better to use cheap components for actuators and sensors because it is considered that humanoid contact to obstacles or fall down. We believe that there is a room in the humanoid research that many interesting research can be done using cheap and off-the-shelf components affordable to most research groups. These robot are already introduced which consist of cheap servo modules for radio control model (SM) [4][5]. The hidden name of our project is, in fact, "The Poorman's humanoid project".

Fourth, humanoid should have a well designed exterior. As robot became everyday-life products, exterior designs plays major role in consumer choice. Since most existing research robots are functionally designed with minimal aesthetics, carefully designed robots are not yet exposed to general public, with exception of AIBO[6] and SIG [7]. Also, the exterior contributes to the function as a protector for its mechanical parts. We claim that "robot design" will be the major industrial design field, and wish to present archetype of humanoid design through Pino.

Grounding to these four issues, we develop the humanoid robot Pino.

2 Exterior design

2.1 Reasons for Designing the Humanoid Robot

What reasons are there for designing the humanoid a robot? Existing humanoid robot research centers on either the development of a humanoid machine from a mechanical engineering approach or, conversely, an analytic machine

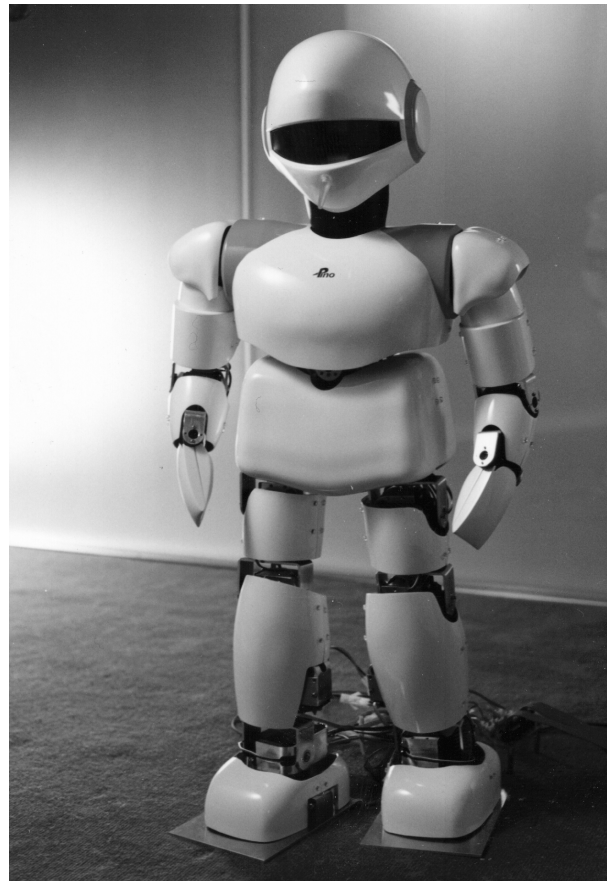

Fig. 1. Whole view of Pino

by which the mechanisms of thought - or intelligence can be simulated and put into effect by a freely moving body reacting to diverse sensory information.

However disparate the means by which humanoid robot research has evolved, both are concerned with the human form as representative of its mechanical features. Aesthetics, we believe, will play an even larger role in the design requirements of the robot in order to grow as an industry the way automobiles and computers have evolved - the aesthetic element playing a pivotal role in establishing harmonious co-existence between the consumer and the product. Accordingly, research that employs an element of aesthetics was considered also as a technological issue and inseparable from the robot's primary mechanical functions.

2.2 Direction of the relation between robots and humans

The next generation of robot research will study the formation of relations between humans and humanoids. The exterior design of the robot will be integral to clarifying its diverse mechanical functions and asserting its autonomy - distinct from that of a mere object. It is this distinction that will enable humans to interact meaningfully with the robot. The designer now has to strive towards designing the relationship between the human and the robot. Traditionally, robotic systems have necessitated by the nature of its inner mechanisms the dynamic by which the robot is appraised from the standpoint of the human gazing upon an object. The exterior design of the robot has transformed this notion by subverting the viewpoint so that the object is looking back at the human; thus creating in between a spatial dimension previously unexplored in the research of humanoid robot design.

Primarily, engineering factors have determined the humanoid form the most expedient in robot design. For robots to be successfully integrated into human society their primary mobile functions will have to negotiate the same obstacles encountered by humans in daily life. In their role of aiding disaster relief and other potentially lethal employment, they will require the optimal mobility afforded by the human form in a human-designed landscape.

However, taking robotics a step further; the robot as a coveted consumer item reflecting the desires and aspirations of its user, it is necessary to reflect upon a system of aesthetic standards to be employed for the user to assert

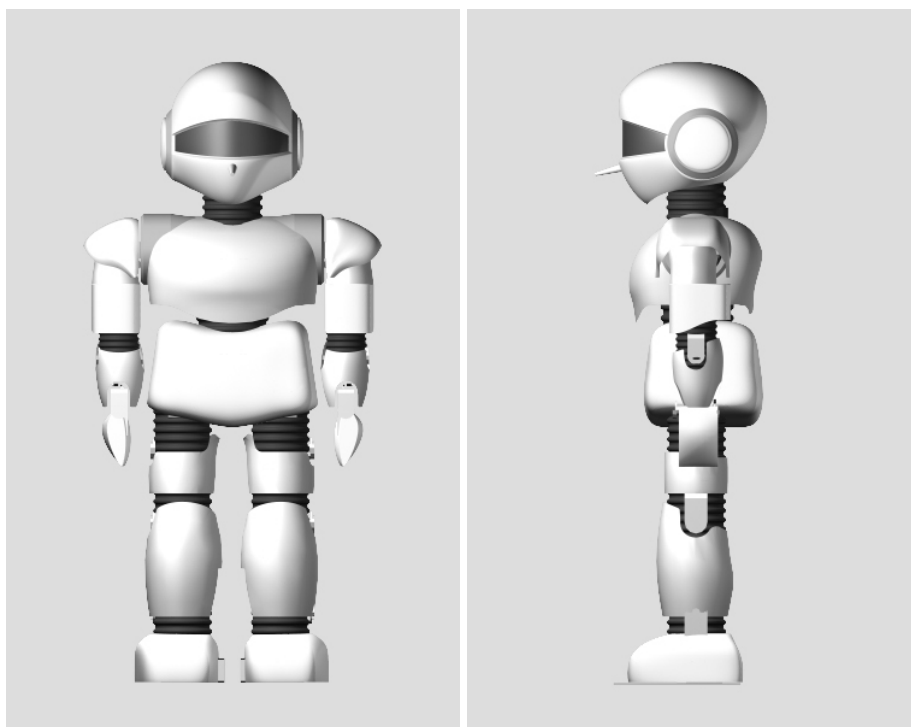

(a) Front view

(b) Side view

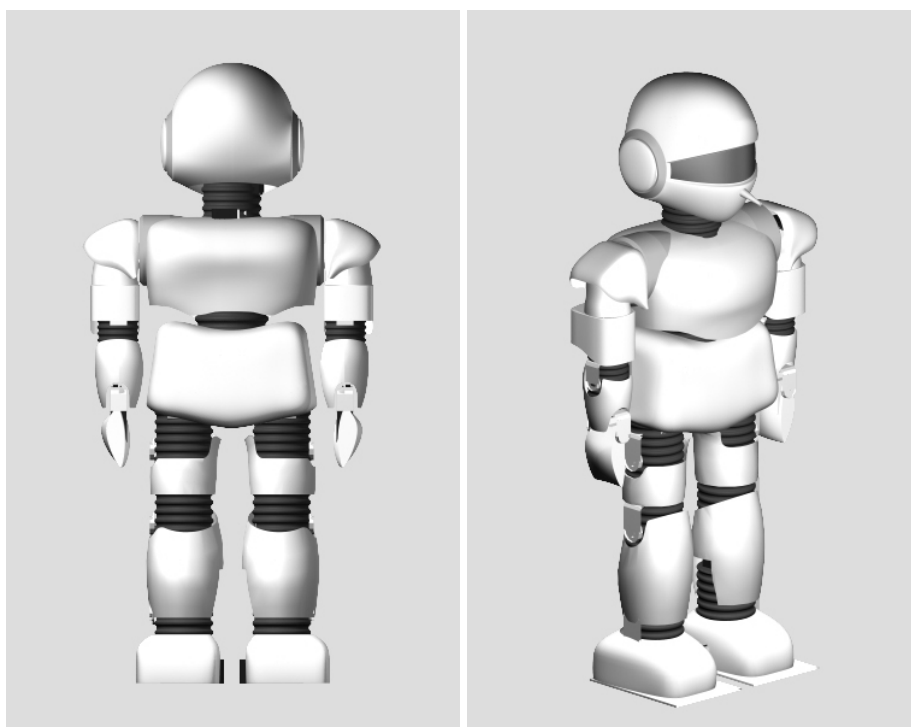

(c) Back view

(d) Bird view

Fig. 2. Image CG design of Pino

possession by means of psychological affiliation with the object. Thus the design must conform to the variable expectations of the user. In some cases the user may identify with the object on the basis of an aesthete: is this form compatible with already existing notions of beauty? Can this form be visualized in the context of "great art"? In other cases the user may project upon the object his or her longings for something entirely different; whether it be basic companionship or possession of yet another desirable in status terms gadget.

The relationship between robots and humans is a factor that designers have to explore more deeply for the successful integration of one into the society of the other. Indeed the mere inclusion of the robot in society in this century is not enough to sustain a lasting or particularly harmonious relationship between the two. For the robot to evolve from object to entity we need to address its genesis in purely human terms as we did with Pino, the humanoid robot who shares an ancestral link with Pinocchio - the puppet who aspired, through artificial means to be a boy, or more specifically, human.

2.3 Necessity of Exterior Design

Pino, the humanoid robot was developed in anticipation of the RoboCup Humanoid League. The importance of exterior design is connected first and foremost to the protection of its inside system in much the same way a car or computer is similarly shielded from contact. Still, providing a mere protective shield to reduce the risk of damage to its inner systems during performance could not sufficiently express our research direction which aims to express the role of the humanoid robot in society in the future. Thus our method towards the aim of giving meaning to the existence of the robot necessitated the creation of a story to explain not only its design elements but its role in a society of the future.

2.4 Robot Design-"PINO" the Design Concept

Before Pino went into development, we discussed what form, and just as importantly what size would be necessary to ensure its comfortable integration into the human home. Its size, we discovered was a very specific element of our design research that was carried out simultaneously during our primary research into its walking functions. The scale of a fully grown adult posed a threatening presence and would, we believed cause a general sense of unease, being less a companion than a cumbersome and overpowering mechanical object. Thereupon, we judged the ideal size for such a robot would be 70 [cm] tall; the approximate size of a one year old child taking its first steps. As for form, it was deemed necessary to design its proportions as recognizably human as possible; deviating too far from the instantly recognizable form of a human child could cause it to be seen as an altogether different object. From a psychological point of view, we noted that even the casual observer focused more attentively, and ultimately more affectionately upon a similarly structured form.

2.5 The origin of the PINO name

Before starting the design sketches we searched for a universal element in the representation of the human form. Images handed down from the archives of such representational forms, we believed, provided the key to integrating into the future what has universally been acknowledged as fundamental beauty. Ancient Greek sculptures and more significantly, as it turned out, the more folkloric marionettes to name a few were evoked, not only for their obvious beauty, but just as importantly for their mournful aspirations towards perfection. The marionette, with its mechanisms to facilitate movement and expression provided the ideal framework by which Pino could be adapted. Pinocchio, whose story needs no explaining, seemed an apt metaphor for our search for human qualities within the mechanical structures of our creation. We felt the necessity to place Pino somewhere in time, more specifically within the context of a story to elevate him above the static realm of the object. For this reason the infant sized cherub was discarded as a possibility despite the temptingly poetic implications of such a creature. An angel, knowing only flight finds his legs useless appendages, and Pino, whose primary function is walking, is unsuited for such dimensions. In his gestation, Pino symbolically expresses not only our desires but humankind's frail, uncertain steps towards growth and the true meaning of the word human.

3 Structure of PINO

3.1 Configuration of DOFs

Humanoid should have high DOFs to realize various kinds of behaviors. In Robocup, for example, it search a ball and two goals, and moves to its desired location with avoiding many obstacles. Then it shoots or passes the ball.

These maneuver mainly involve following four fundamental motions; (1) keeping its body's balance, (2) moving the swing leg, (3) operating a grasping object, and (4) controlling visual attention.

To keep its body's balance, it needs 6 DOFs which denote motions of a center of gravity of itself. It also needs 6 DOFs to move the swing leg to its arbitrary location. Handling or operating a grasping object needs 6 DOFs, too. Controlling its visual attention needs 6 DOFs to move the visual sensor to arbitrary positions and orientations. Therefore humanoid needs 24 DOFs to achieve these motions in parallel. Thus, we decided the configuration of Pino as follows. Each leg has 6 DOFs, each arm has 5 DOFs, the neck has 2 DOFs and the trunk has 2 DOFs. Totally Pino has 26 DOFs (see Fig.3).

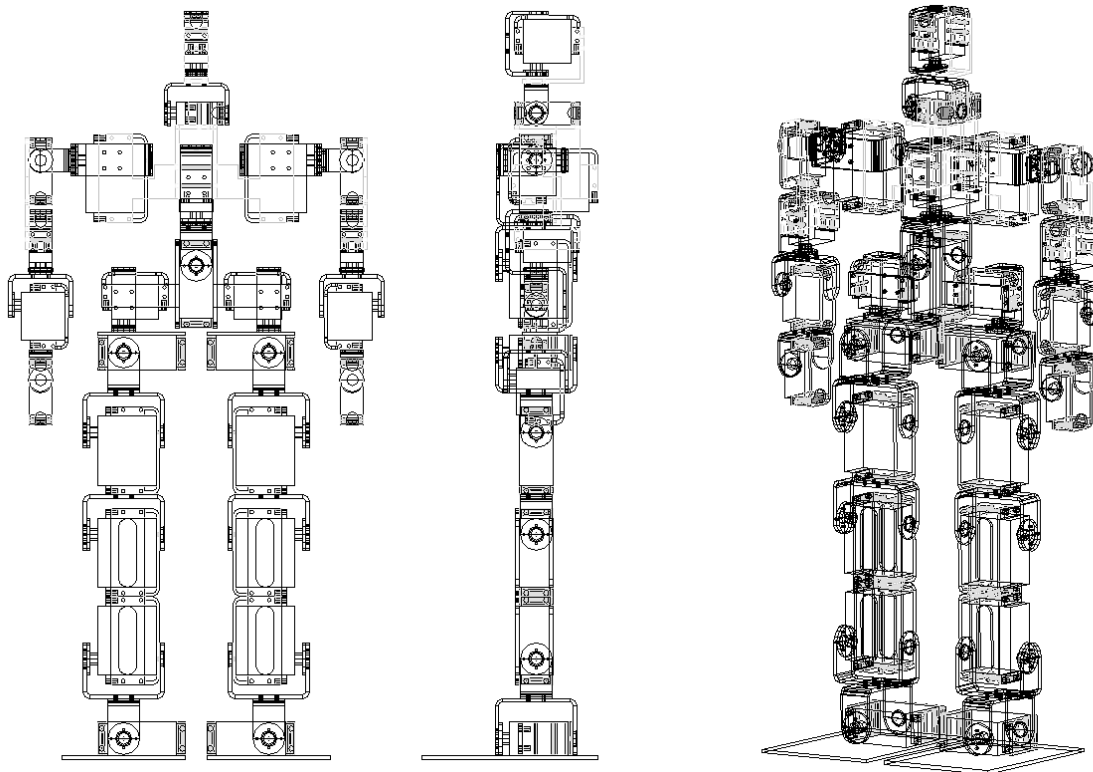
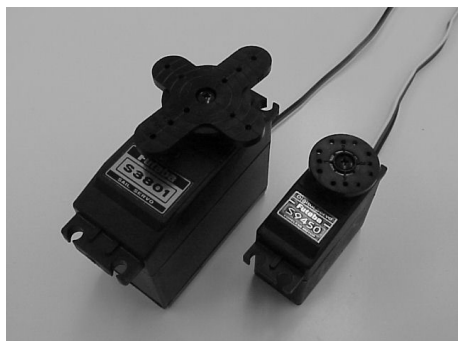

Fig. 3. Mechanical design

3.2 Actuators and Sensors

Pino has 26 motors which correspond to the number of DOFs. And it needs various kinds of sensors, for example, visual sensor for recognizing objects, posture sensor for detecting its body's balance, force and tactile sensor for detecting contact to others and falling down, and so on. It is better to use cheap components for actuators and sensors because it is considered that humanoid contact to obstacles or fall down. There are SMs as a cheap, compact and high torque servo motor. These SMs built in gearhead and its position controller, and these servo loops run at 50 [Hz]. We adopted two kind of SMs (vender Futaba) for Pino which torque are 20 [kg·cm] and 8 [kg·cm] (see Fig.4 (a)). All of their gears are changed to metal for reinforcement them against high torque (see Fig.4 (b)). Pino has 8 force sensors (FSR) (see Fig.4 (c), (d)) attached to each foot which can obtain foot forces, and has a posture sensor on chest so that it can sense its body's posture. We also use potentiometers in SMs as joint angle sensors. Pino also has a vision sensor mounted on head (see Fig.4 (e)). All information of these sensors are sent to host computer via A/D converters (AD12-64(PCI), vender CONTEC) and frame grabber (GV-VCP2/PCI, vendor I/O DATA Japan). From input image source obtained by frame grabber, color objects is detected. It is shown an example of color image in Fig.5. In this image, there are four color samples, red ball, yellow and blue plate, and green floor. Triangle marks in Fig.5 (b) denote center of each color region.



(a) Servo module

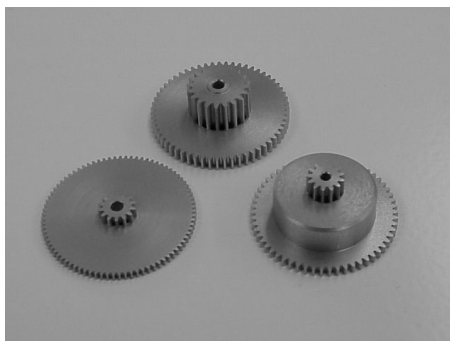

(b) Metal gears



(c) Force sensor (FSR)

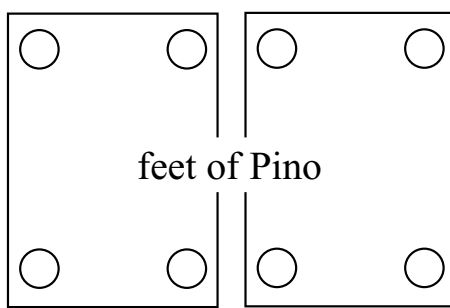

○ : force sensor (FSR)

(d) Configuration of FSR



(e) Vision sensor

Fig. 4. Actuators and sensors for Pino

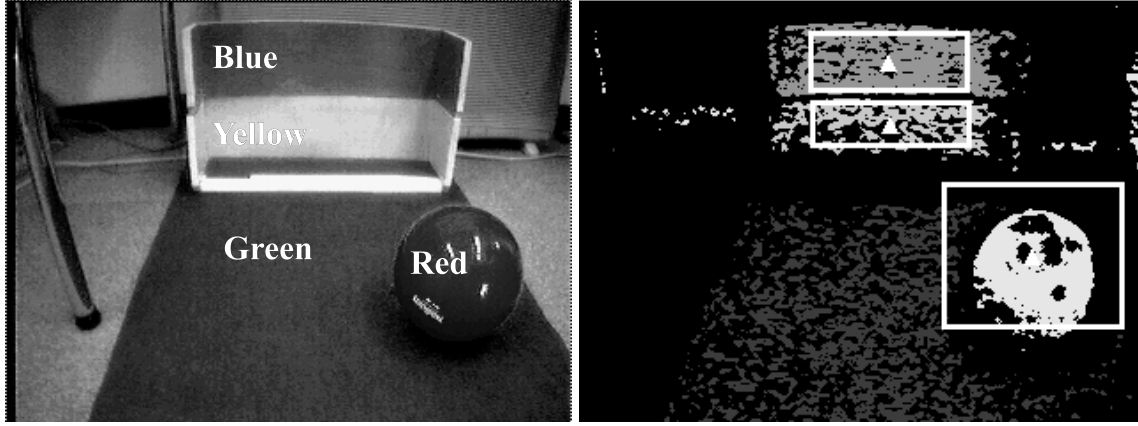

(a) Input image source

(b) Detected objects using color

Fig. 5. Color detection from input image source

3.3 Processing system

The control system for Pino consists of a host computer and a controller of SMs. The host computer obtains all information of sensors via A/D converters and tracking vision board. The host computer consists of Pentium III 733 [MHz] processors and 512 [MByte] memory, and its operating system (OS) is realtime OS (RT-Linux). From these information of sensors, the host computer calculate angular velocity of each joint on realtime. Pino also has controller of itself which consists of a RISC micro-computer SH2 (SH7050, vender Hitachi) and its slave Programmable Logic Device (Flex10K30AQC240-3, hereafter PLD, vender ALTERA). This controller communicates the host computer via RS-232C. The PLD has 26 submodules of SM controller in it. Each submodule generates position commands for SM. The servo loops run at 50 [Hz], and the position commands for 26 SMs are updated simultaneously. We can use the development tool for this PLD for free. Also, power resource is supplied with external energizer.

4 Control for the PINO

Actuators of Pino consist of 26 sets of motor and its driver for position control. However, speed control is more useful for controlling dynamic motions. Therefore, in order to realize speed control with them, we make quasi speed control system by utilizing direct kinematics of Pino and Jacobian matrices which denote velocity relationships between joint angles and positions and posture of each foot with respect to a robot coordinate frame fixed to the robot body. In this section, we explain the foot position controller of the Pino briefly.

Let $\Sigma_R, \Sigma_{R*}, \Sigma_{L*}, l_{R*}, l_{L*}, {}^R p_{RE}, {}^R p_{LE}, {}^R R_{RE}$ and ${}^R R_{LE}$ denote a robot coordinate frame fixed to the robot body, link frames, link lengths of right and left legs, positions and rotation matrices of right and left legs with respect to the robot coordinate frame, respectively (see Fig.7). We can calculate homogeneous coordinate transformation matrices, ${}^R T_{RE}$ and ${}^R T_{LE}$ which denote the positions and posture of each foot with respect to Σ_R ,

$${}^R T_{RE} = \begin{bmatrix} {}^R R_{RE} & {}^R p_{RE} \\ O & 1 \end{bmatrix} = {}^R T_{R0} {}^{R0} T_{R1}(\theta_{R1}) \cdots {}^{R5} T_{R6}(\theta_{R6}) {}^{R6} T_{RE}, \quad (1)$$

$${}^R T_{LE} = \begin{bmatrix} {}^R R_{LE} & {}^R p_{LE} \\ O & 1 \end{bmatrix} = {}^R T_{L0} {}^{L0} T_{L1}(\theta_{L1}) \cdots {}^{L5} T_{L6}(\theta_{L6}) {}^{L6} T_{LE}, \quad (2)$$

where ${}^i T_j$ denotes homogeneous coordinate transformation matrix from Σ_j to Σ_i calculated from link parameters. Differentiating equations (1) and (2), we can obtain velocity relationship between $\dot{\theta} = [\dot{\theta}_{R1} \cdots \dot{\theta}_{R6} \dot{\theta}_{L1} \cdots \dot{\theta}_{L6}]^T \in \mathfrak{R}^{12}$ and ${}^R \dot{r} = [{}^R \dot{p}_{RE} \quad {}^R \omega_{RE} \quad {}^R \dot{p}_{LE} \quad {}^R \omega_{LE}]^T \in \mathfrak{R}^{12}$,

$${}^R \dot{r} = J_{r\theta}(\theta) \dot{\theta}, \quad (3)$$

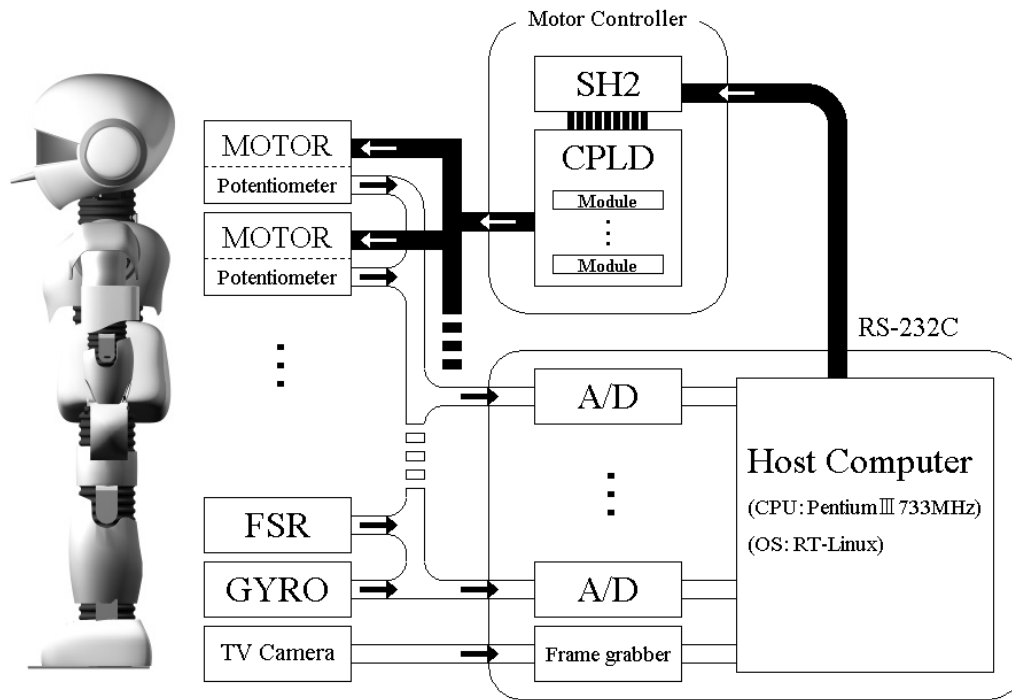

Fig. 6. System configuration

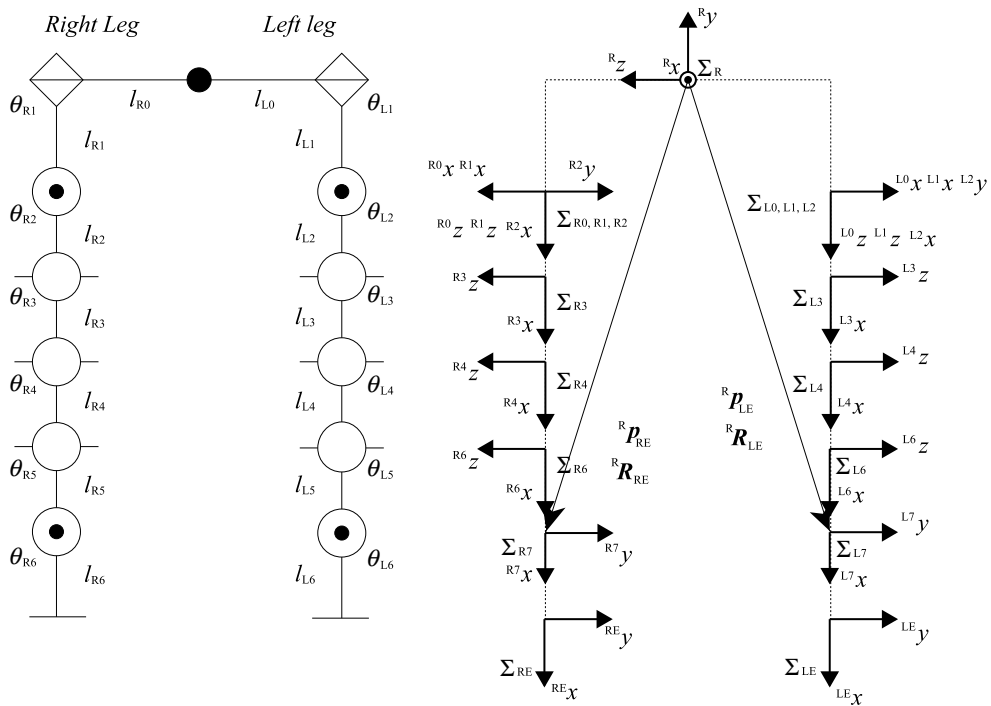

Fig. 7. Coordinate frames of legs of the Pino

where ${}^R\omega_i$ and $\mathbf{J}_{r\theta}(\theta)$ denote angular velocity vector of Σ_i with respect to Σ_R and $\partial {}^R\mathbf{r}/\partial \theta \in \mathbb{R}^{12 \times 12}$, respectively. From equation (3), a feedback controller for joint velocities to move each foot to desired positions ${}^R\mathbf{r}_d$ can be derived as

$$\mathbf{u}_r = \mathbf{J}_{r\theta}^+ \mathbf{K}_r ({}^R\mathbf{r}_d - {}^R\mathbf{r}) + (\mathbf{I}_{12} - \mathbf{J}_{r\theta}^+ \mathbf{J}_{r\theta}) \mathbf{k}, \quad (4)$$

where $\mathbf{J}_{r\theta}^+$, \mathbf{K}_r , \mathbf{I}_{12} and \mathbf{k} denote a pseudo inverse matrix of a matrix $\mathbf{J}_{r\theta}$, a gain matrix, a 12×12 identity matrix and an arbitrary vector that describes redundancy of the robot with respect to this serving task. An input vector of the actuators of Pino is, however, a joint angular vector. Therefore we make the input vector by multiplying \mathbf{u}_r by sampling rate ΔT and adding previous joint angular vector. The block diagram of it is shown in Fig.8. If

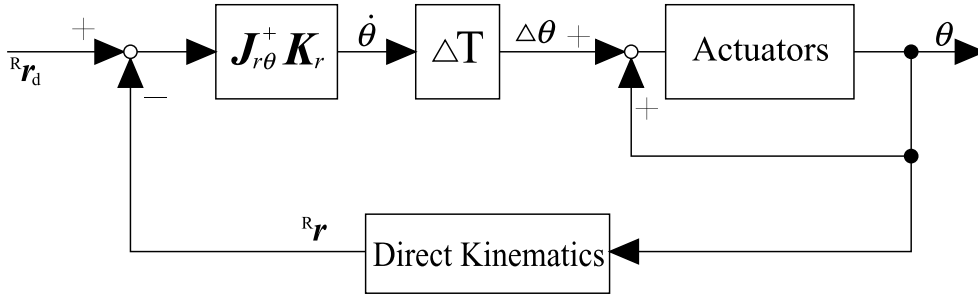

Fig. 8. A block diagram of controlling foot positions

Pino goes into the real world and achieve their complicated tasks described in section 1, it needs capabilities to generate many motions and adapt to various situations of the environment. In previous work for the legged robot, Miyashita et al. [8] proposed a reflexive walk of a quadruped robot based on reflexes to realize an adaptive walk in a dynamic environment. They applied two reflexes, a vision-cued swaying reflection and a reflective gait, to the robot. A combination of them makes the robot walk reflexively without programming the exact motion of each joint of the legs.

4.1 Control of swaying motion [9]

Pino has to sway its body without lifting legs so as to maintain its body stability. In order to realize the swaying motion, we apply a method which proposed by Hosoda et al. [9] to our biped robot. Following this subsection, we explain it briefly.

As we can see in Fig. 9, the biped robot becomes a closed linkage system. Therefore, we have to consider not only one leg, but also all legs of the robot to control the positions and posture of its body. Hereafter we assume that the legs of the robot contact with the ground at points with friction. Let Σ_O , ${}^O\mathbf{p}_R$, and ${}^O\mathbf{R}_R$ be a world coordinate frame fixed on the ground, a position and a rotation matrix of Σ_R with respect to Σ_O , respectively. We can obtain vectors from the origin of Σ_O to each foot with respect to Σ_O , ${}^O\bar{\mathbf{p}}_{RE}$ and ${}^O\bar{\mathbf{p}}_{LE} \in \mathbb{R}^3$, as

$${}^O\bar{\mathbf{p}}_{RE} = {}^O\mathbf{p}_R + {}^O\mathbf{R}_R {}^R\mathbf{p}_{RE}, \quad \text{and} \quad (5)$$

$${}^O\bar{\mathbf{p}}_{LE} = {}^O\mathbf{p}_R + {}^O\mathbf{R}_R {}^R\mathbf{p}_{LE}. \quad (6)$$

If each leg is not lifted, we can assume that ${}^O\bar{\mathbf{p}}_{RE}$ and ${}^O\bar{\mathbf{p}}_{LE}$ are constant vectors. Differentiating equations (5) and (6) under this assumption, we can get following relations,

$${}^O\dot{\bar{\mathbf{p}}}_{RE} = {}^O\dot{\mathbf{p}}_R + {}^O\mathbf{R}_R {}^R\dot{\mathbf{p}}_{RE} + {}^O\boldsymbol{\omega}_R \times ({}^O\mathbf{R}_R {}^R\mathbf{p}_{RE}) = 0 \quad \text{and} \quad (7)$$

$${}^O\dot{\bar{\mathbf{p}}}_{LE} = {}^O\dot{\mathbf{p}}_R + {}^O\mathbf{R}_R {}^R\dot{\mathbf{p}}_{LE} + {}^O\boldsymbol{\omega}_R \times ({}^O\mathbf{R}_R {}^R\mathbf{p}_{LE}) = 0, \quad (8)$$

where ${}^O\boldsymbol{\omega}_R$ denote a angular velocity vector of Σ_R with respect to Σ_O . From equations (7) and (8), we can obtain

$$\begin{aligned} {}^R\dot{\mathbf{p}}_{RE} &= -{}^O\mathbf{R}_R^{-1} \{ {}^O\dot{\mathbf{p}}_R + {}^O\boldsymbol{\omega}_R \times ({}^O\mathbf{R}_R {}^R\mathbf{p}_{RE}) \} \\ &= \begin{bmatrix} -{}^O\mathbf{R}_R^T & {}^O\mathbf{R}_R^T \{ ({}^O\mathbf{R}_R {}^R\mathbf{p}_{RE}) \times \} \end{bmatrix} \begin{bmatrix} {}^O\dot{\mathbf{p}}_R \\ {}^O\boldsymbol{\omega}_R \end{bmatrix}, \quad \text{and} \end{aligned} \quad (9)$$

$${}^R\dot{\mathbf{p}}_{LE} = \begin{bmatrix} -{}^O\mathbf{R}_R^T & {}^O\mathbf{R}_R^T \{ ({}^O\mathbf{R}_R {}^R\mathbf{p}_{LE}) \times \} \end{bmatrix} \begin{bmatrix} {}^O\dot{\mathbf{p}}_R \\ {}^O\boldsymbol{\omega}_R \end{bmatrix}. \quad (10)$$

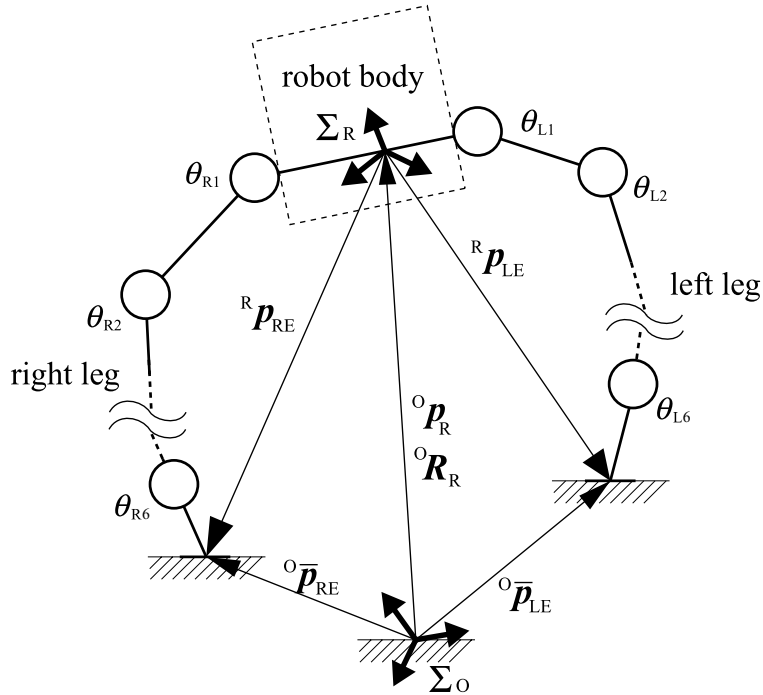

Fig. 9. Closed loop of the biped robot and the world coordinate frame

Thus we can get a velocity relationship between positions of each foot and a position and posture of Σ_R with respect to Σ_O as

$${}^R \dot{\mathbf{p}} = \mathbf{J}_{pr} {}^O \dot{\mathbf{r}}_R, \quad (11)$$

where

$$\begin{aligned} {}^R \dot{\mathbf{p}} &= \begin{bmatrix} {}^R \dot{\mathbf{p}}_{RE}^T & {}^R \dot{\mathbf{p}}_{LE}^T \end{bmatrix}^T, \\ \mathbf{J}_{pr} &= \begin{bmatrix} -{}^O \mathbf{R}_R^T & {}^O \mathbf{R}_R^T \{({}^O \mathbf{R}_R {}^R \mathbf{p}_{RE}) \times\} \\ -{}^O \mathbf{R}_R^T & {}^O \mathbf{R}_R^T \{({}^O \mathbf{R}_R {}^R \mathbf{p}_{LE}) \times\} \end{bmatrix}, \text{ and} \\ {}^O \dot{\mathbf{r}}_R &= \begin{bmatrix} {}^O \dot{\mathbf{p}}_R \\ {}^O \boldsymbol{\omega}_R \end{bmatrix}. \end{aligned}$$

From eq. (11), a feedback controller for velocities of each foot to sway the body can be derived as

$$\mathbf{u}_{O_r} = \mathbf{J}_{pr} \mathbf{K}_{O_r} ({}^O \mathbf{r}_{Rd} - {}^O \mathbf{r}_R) \quad (12)$$

where \mathbf{K}_{O_r} and ${}^O \mathbf{r}_{Rd}$ denote a gain matrix and a desired position and posture of Σ_R with respect to Σ_O . Combining eq. (4), (12) and a controller to keep the posture of each foot parallel to the horizontal plane, we can realize the swaying motion. The diagram of the swaying controller is shown in Fig. 10.

5 Experiments and Discussion

In this section, We had the preliminary experiment that we made Pino walk to give the trajectory of each joint in order to verify the Pino's system performance. We built a kinematic model of Pino and applied it the controller of positions and posture of each foot described in section 4. We assume that the motion sequence of one cycle of walking consists of 6 phases (see Fig.11). We generated the trajectories based on the motion sequence in advance. The example of trajectories of each joint is shown in Fig.12. We gave the trajectory of each joint to Pino, and made it walk in the real environment. As the result, Pino can walk based on them. Fig.12, Fig.13 show the first step of the result of this experiment.

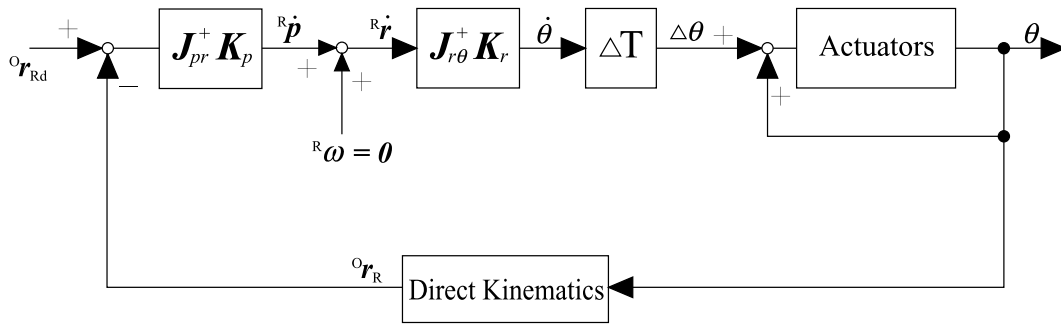

Fig. 10. A block diagram of the swaying controller

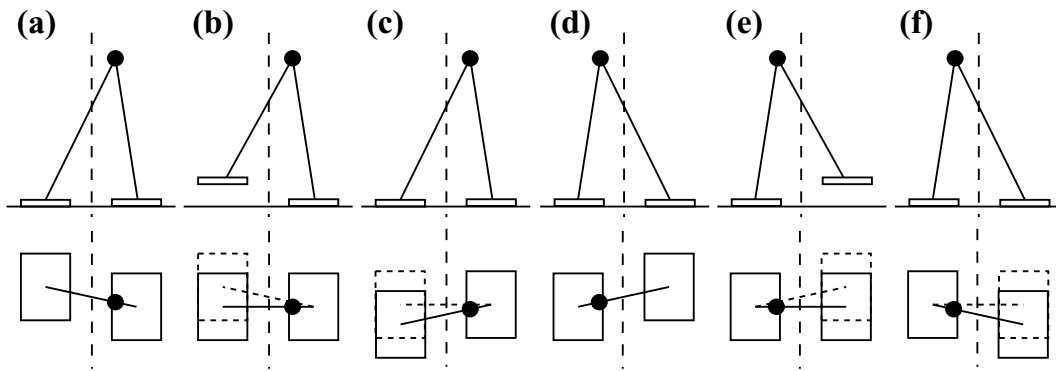

Fig. 11. The motion sequence of one cycle

In this experiment, Pino often falls down because we only use the interoceptive information. Therefore it needs to use exteroceptive information in order to realize adaptive walk. Besides, it needs to make the online system which can generate various kind of behavior using them.

6 Conclusion

In this paper, we described how we approach our issues within Pino the humanoid. Pino was designed so that it is enable for most researchers to study for the RoboCup Humanoid League or humanoid researches. It consists of 26 SMs, 8 force sensors, a posture sensor, a vision sensor and its control system. All of them consist of cheap and off-the-shelf components. Also, Pino has a well designed exterior. We make Pino's exterior using laser beam lithography method. The method enable us to make the exterior with the curved surface made of polyurethane resin, and through this shape it's very high stiffness. In the preliminary experiments, we verified the performance of Pino that it can walk in the real environment.

In the future work, we would like to make the online system which can generate various kind of behavior based on exteroceptive information using a vision sensor, force sensors, a posture sensor and joint sensors.

References

1. Kitano, H., Asada, M.: RoboCup Humanoid Challenge: That's One Small Step for A Robot, One Giant Leap for Mankind. Proc. of International Conference on Intelligent Robots and Systems (IROS-98) (1998)
2. Hirose, M., Takenaka, T., Gomi, H., Ozawa, N.: Humanoid Robot. The Journal of the Robotics Society of Japan (JRSJ) vol.15, no.7 (1997) (in Japanese)
3. Yamasaki, F., Matsui, T., Miyashita, T., Kitano, H.: PINO The Humanoid : A Basic Architecture. Proc. of The Fourth International Workshop on RoboCup (2000)
4. Inaba, M., Kanehiro, F., Kagami, S., Inoue, H.: Two-armed Bipedal Robot that can Walk, Roll Over and Stand up. Proc. of International Conference on Intelligent Robots and Systems (IROS-95) (1995)

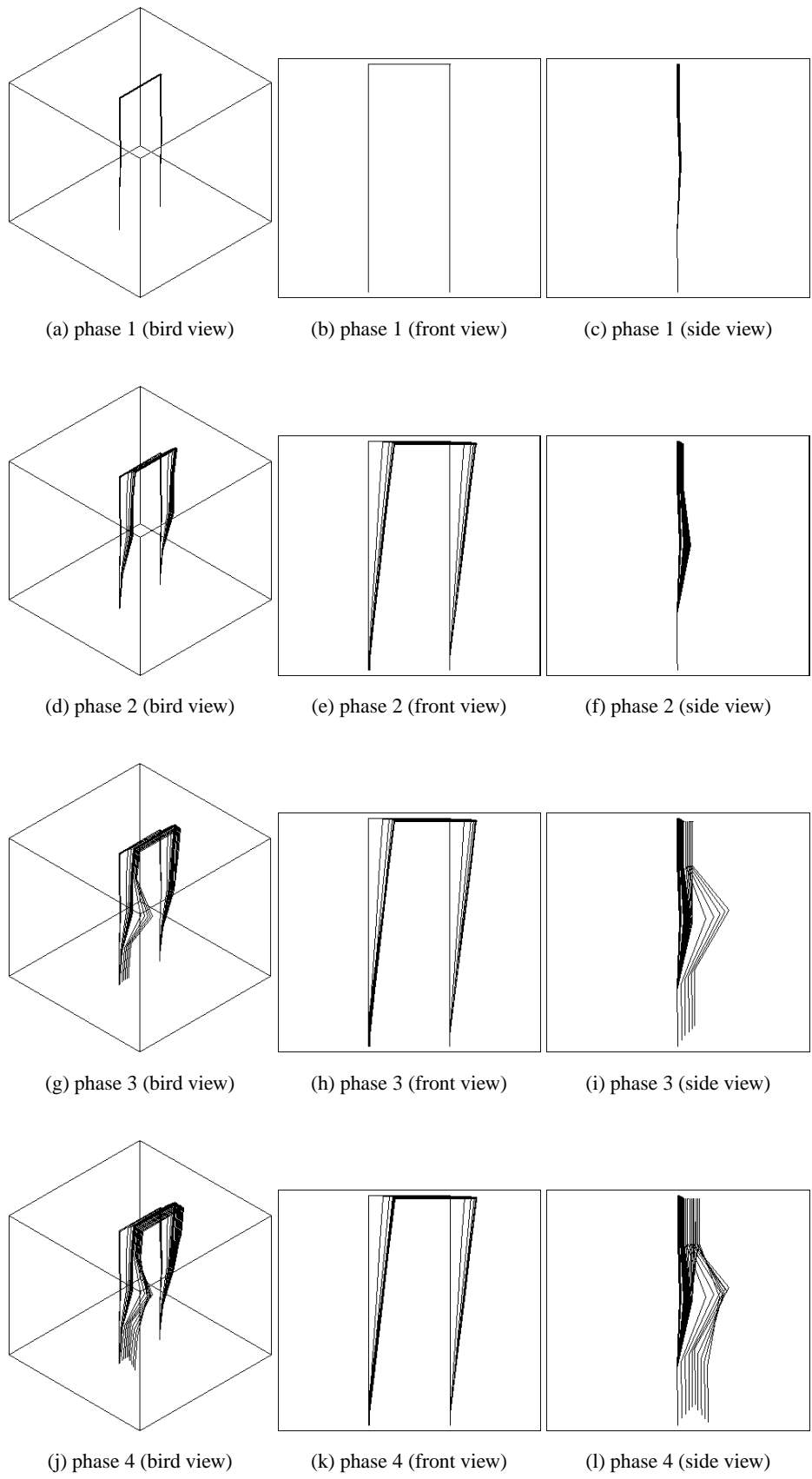
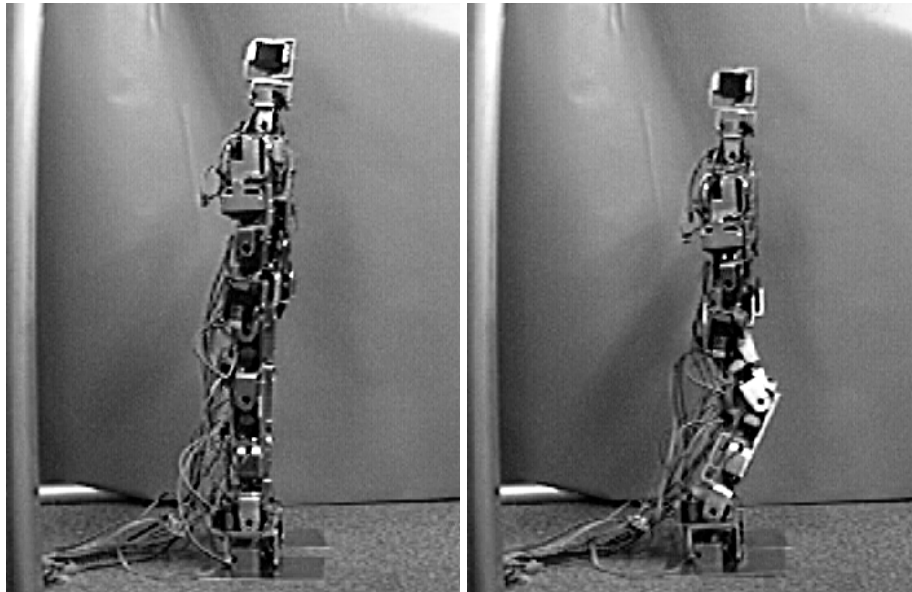
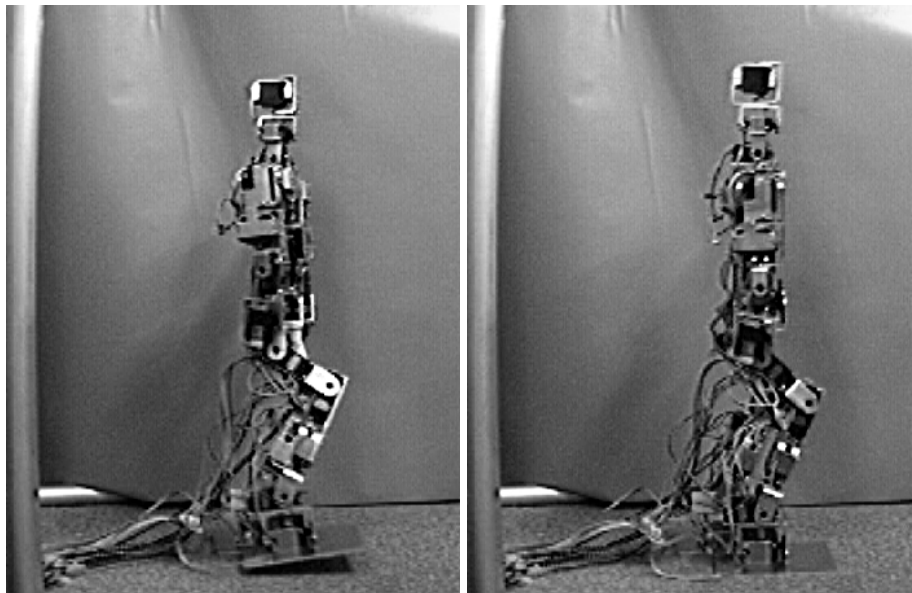

Fig. 12. Trajectories of each joint (the first step)



(a) phase 1

(b) phase 2



(c) phase 3

(d) phase 4

Fig. 13. Experimental result (the first step)

5. Inaba, M., Igarashi, T., Kagami, S., Inoue, H.: A 35 DOF Humanoid that can Coordinate Arms and Legs in Standing up, Reaching and Grasping an Object. Proc. of International Conference on Intelligent Robots and Systems (IROS-95) (1995)
6. Fujita, M., Kitano, H.: Development of an Autonomous Quadruped Robot for Robot Entertainment. *Autonomous Robots*, 5, (1998)
7. Kitano, H., Okuno, H. G., Nakadai, K., Fermin, I., Sabish, T., Nakagawa, Y., Matsui, T.: Designing a Humanoid Head for RoboCup Challenge. Proc. of Agent 2000 (2000)
8. Miyashita, T., Hosoda, K., Asada, M.: Reflective walk based on lifted leg control and vision-cued swaying control. Proc. of 1998 BSME International Symposium on Climbing and Walking Robots (CLAWAR'98) (1998)
9. Hosoda, K., Kamado, M., and Asada, M.: Vision-guided swaying controller for legged robots by visual servoing. *gJournal of the robotics society of Japan*, 17-5 (1999) (in Japanese)